



SINCE 1975

USER MANUAL **LOBSTER TANK**

TABLE OF CONTENT

1. PRODUCT SPECIFICATIONS

- 1.1 Front view
- 1.2 Rear view
- 1.3 Filtration system
- 1.4 Electrical and units

2. HANDLING OF THE TANK

- 2.1 Forklift handling
- 2.2 Required tools

3. INITIAL START-UP

- 3.1 Fill the water
- 3.2 Max level
- 3.3 Electric outlets
- 3.4 Adjust water level
- 3.5 Salt reading
- 3.6 Disgorge lobster
- 3.7 Build bacteria

4. GENERAL MAINTENANCE

- 4.1 Weekly maintenance
- 4.2 Monthly maintenance
- 4.3 Yearly maintenance

5. TROUBLESHOOTING

- 5.1 Salt measurement with hydrometer
- 5.2 Ammonia reading
- 5.3 Disgorge the lobsters
- 5.4 Water level monitoring
- 5.5 Water drain
- 5.6 The water has a weak debit
- 5.7 Algae
- 5.8 Storing the lobster tank
- 5.9 Moving the lobster tank

6. FAQ

WARRANTY

The tank has a one-year warranty starting on the billing date, excluding the following exceptions: if the tank is damaged by misuse, improper installation, poor maintenance, any accidental damages, any modifications, or non-authorized repairs.

NOTE: The product specifications featured below refer to one of our models used as an example describing each part included and explaining how it works. If you didn't receive your product specification, pls request one.

1. PRODUCT SPECIFICATIONS

1.1 FRONT VIEW

STAINLESS STEEL MARINE
GRADE 304 / 16 GAUGE

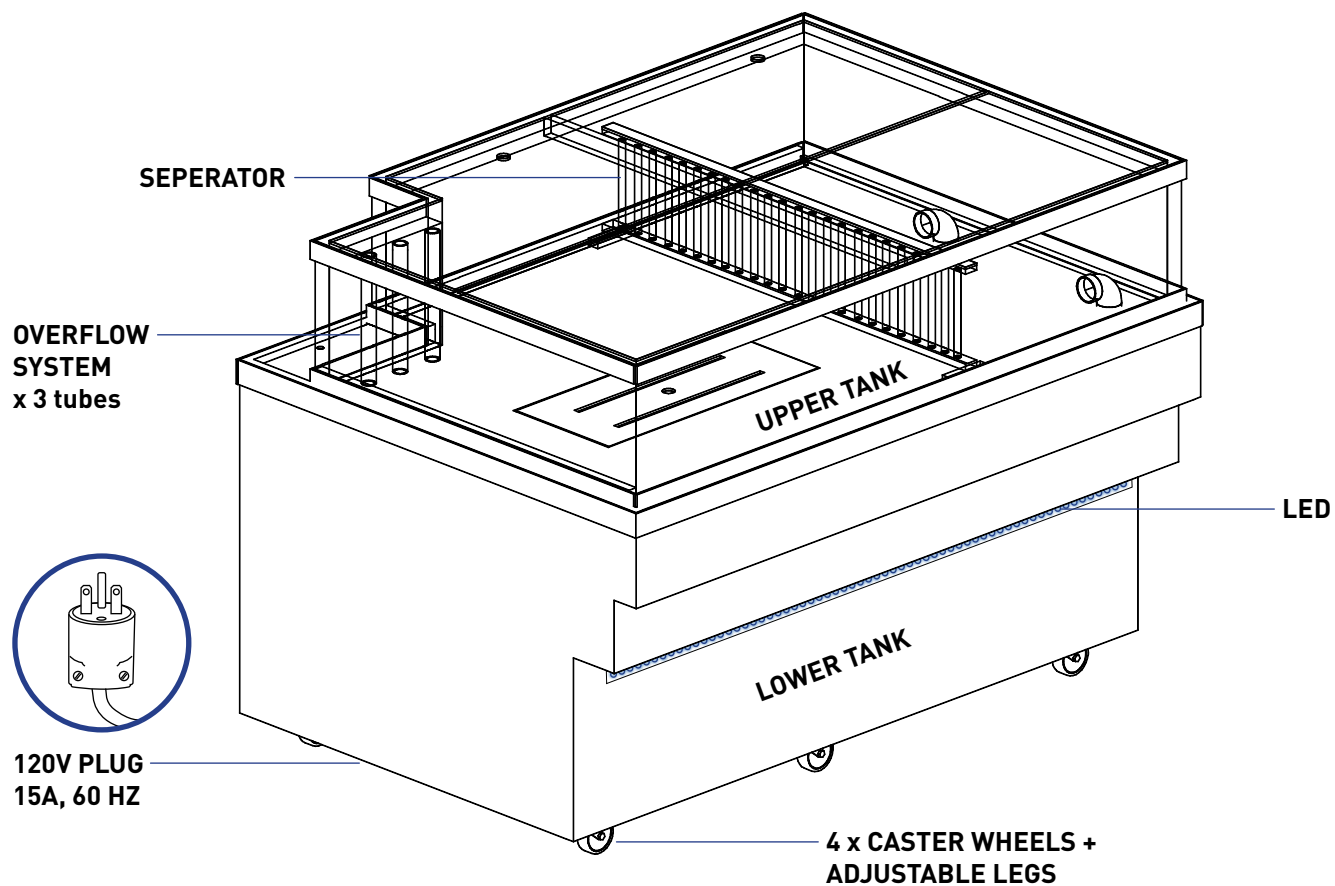

1.2 REAR VIEW

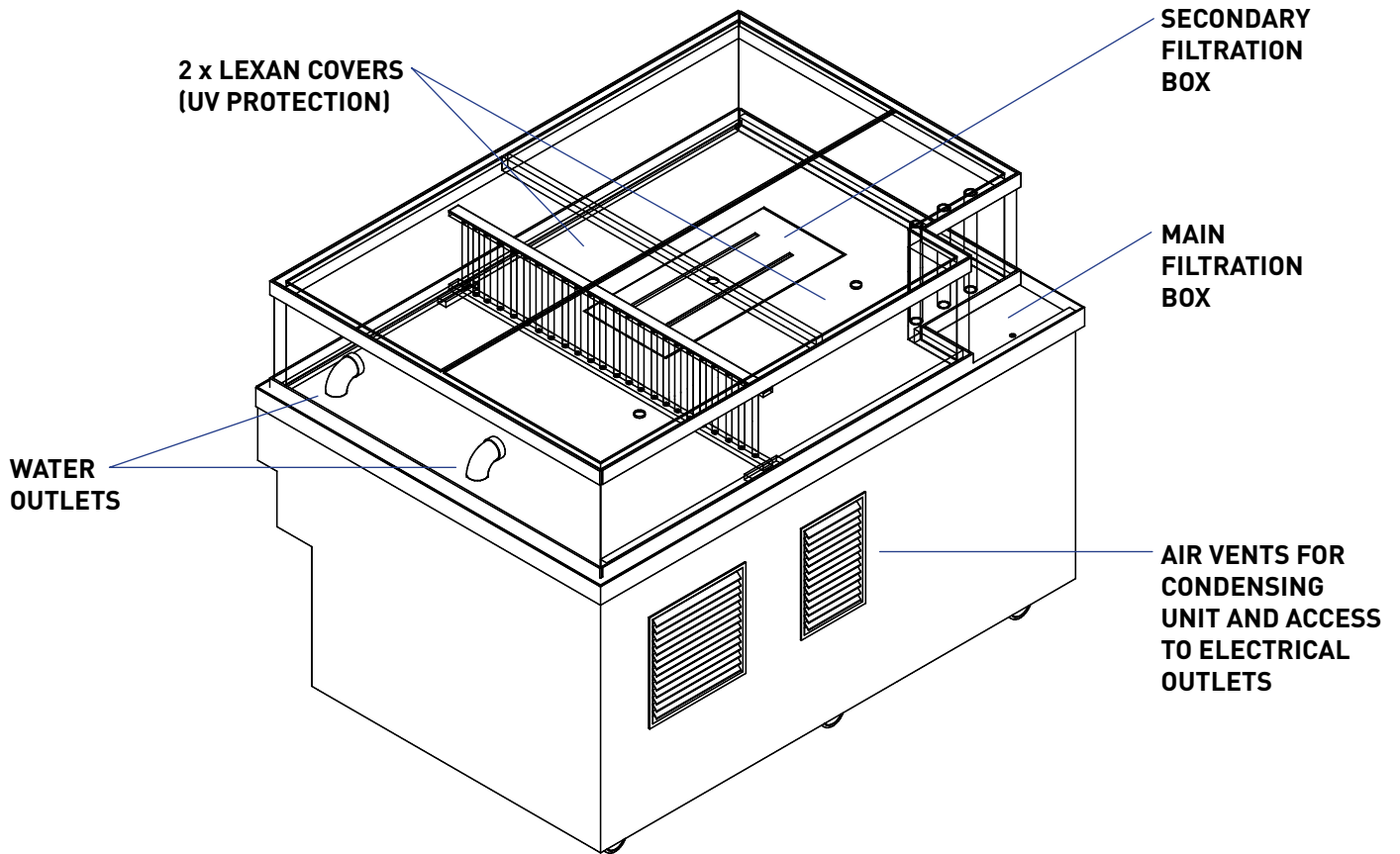

1.3 FILTRATION SYSTEM

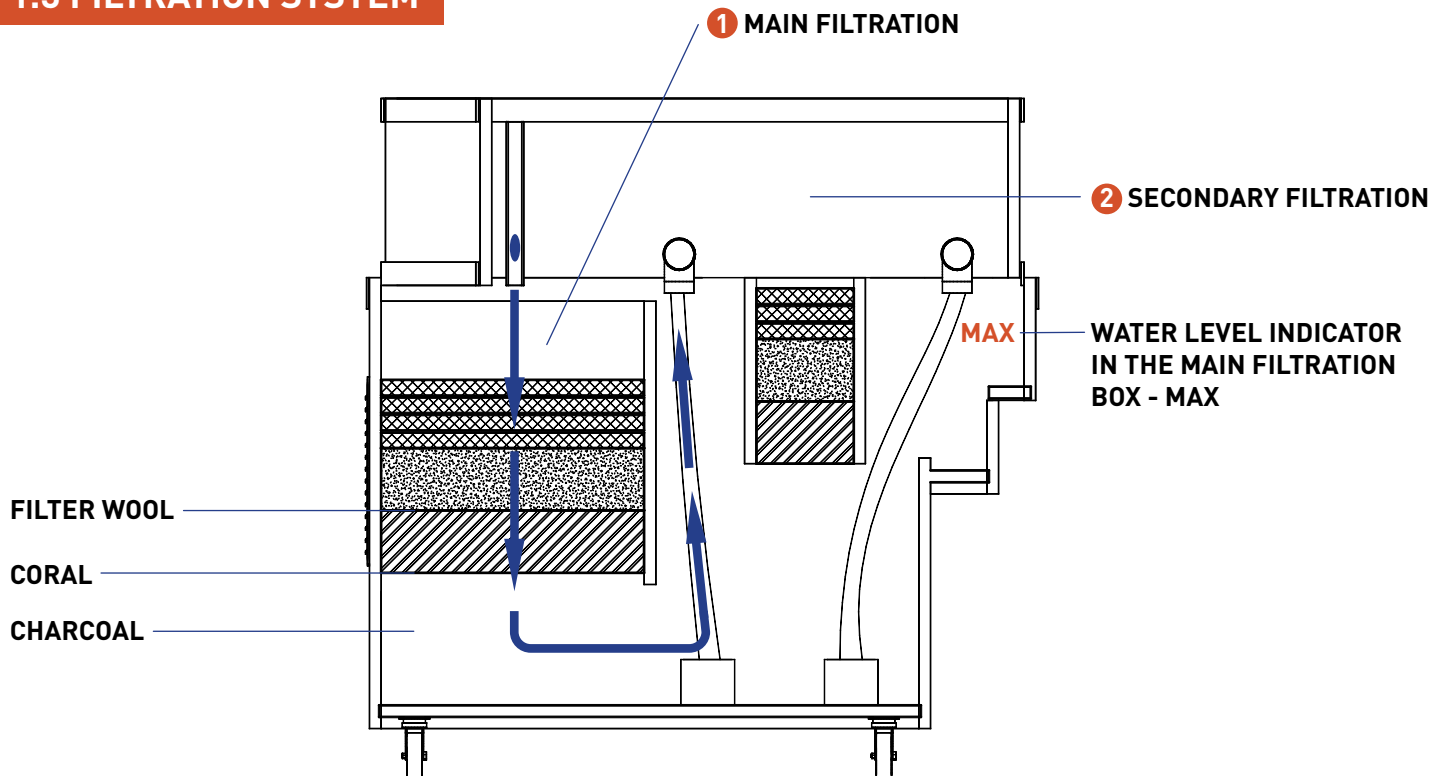

ORGANIC COMPONENTS CREATING AN ECHO SYSTEM:



AQUA'S SALT



FILTERS



ORGANIC CORAL
Washable and reusable for up to 4 years



COAL
Last 1 year

1.3 FILTRATION SYSTEM

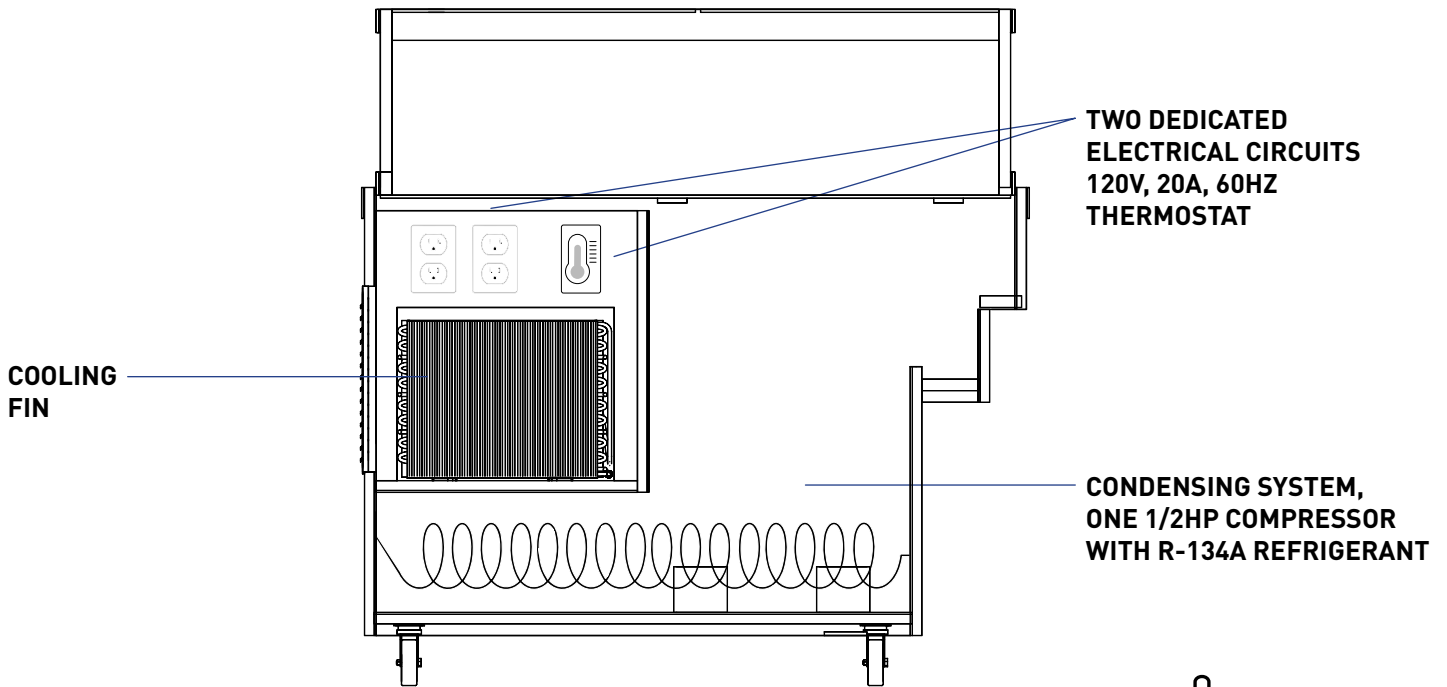

ALSO INCLUDED:

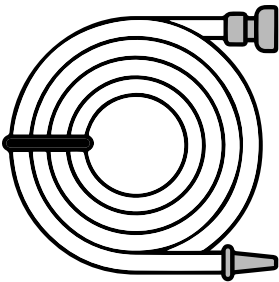

GARDEN HOSE AND FITTING FOR FAUCET

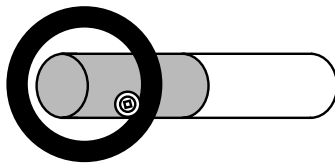

INJECTOR FITTING TO DRAIN THE TANK

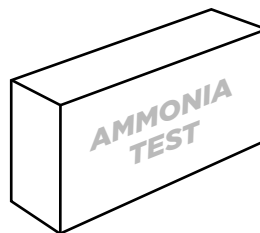

AMMONIA TEST

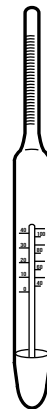

GLASS HYDROMETER TO MEASURE THE SALT LEVEL

2. HANDLING OF THE TANK

2.1 FORKLIFT HANDLING

Ensure to place the four woodblocks (included) between the tank bottom and the lift forks to prevent the stainless steel from bending.

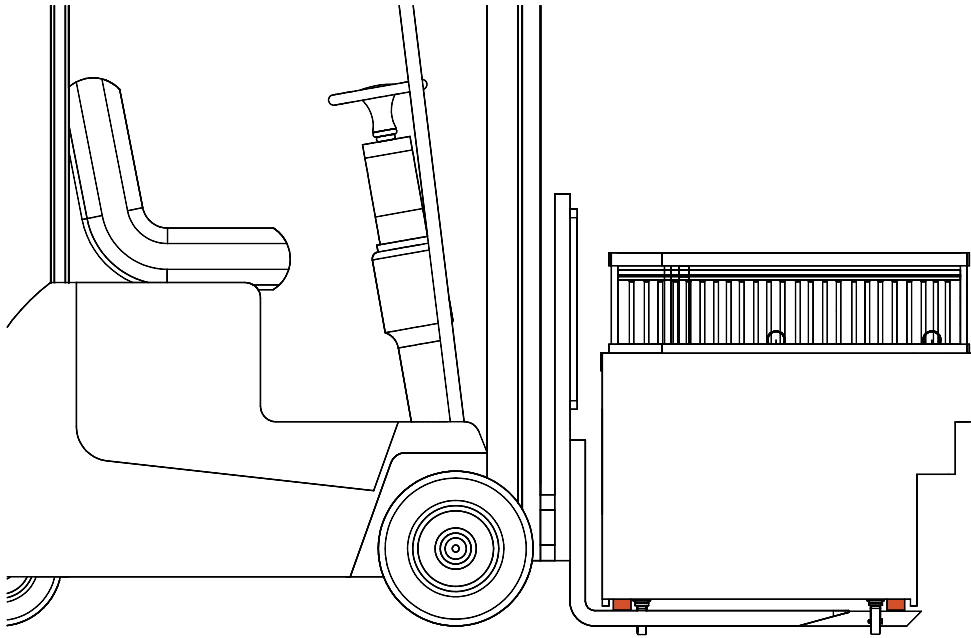

2.2 REQUIRED TOOLS

REQUIRED
TOOLS NEEDED:

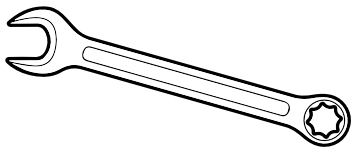

KEY 1-1/8 INCHES

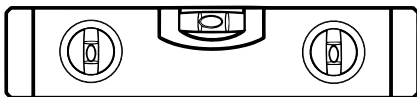

LEVEL



> Make sure to level the tank.
> If the tank isn't leveled correctly,
it will damage it.

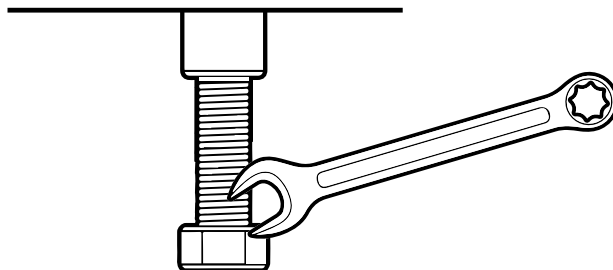

USE THE KEY TO ADJUST
THE LEGS OF THE TANK

3. INITIAL START-UPK



- › Make sure that the air intake where the compressor is located is accessible and not obstructed.
- › Never turn on the electricity of the tank until the lower tank is filled up to the level indicated - MAX.
- › Never fill the water by the upper tank.
- › Never use soap or other types of chemical detergent on the tank.
- › Wash your hands to remove hand sanitizer or cream before handling the tank's water.
- › Do not adjust the thermostat(s), it's been pre-set by the manufacturer.
- › If you won't have lobster in the tank for an extended period, unplug the tank to recede the water to the lower tank.

3.1 FILL THE WATER

Put the hose in the overflow tube and start to fill the water

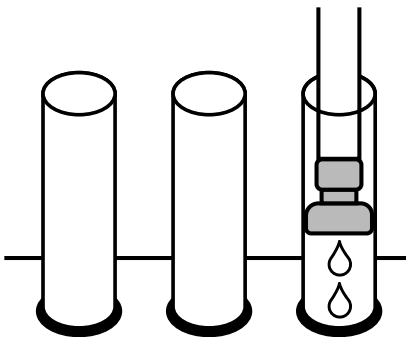

PUMP

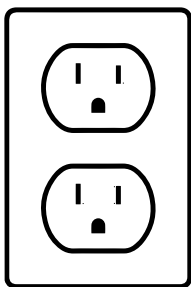

120V

COMPRESSOR

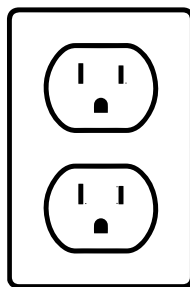

120V

3.2 MAX LEVEL

Put the hose in the overflow tube and start to fill the water

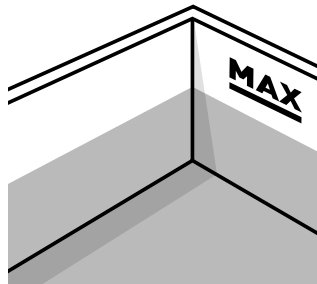

3.3 ELECTRIC OUTLETS

Plug the electrical cable to outlet 120V/20AMP

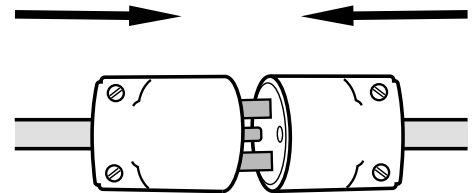

- › Plug the compressor outlet respectively in the COMPRESSOR inlet.
- › Plug the pump outlet respectively in the PUMP inlet.
- › Make sure to plug the proper outlet in the right inlet.
- › Otherwise, it will ruin your pump and compressor!

3.4 ADJUST WATER LEVEL

Adjust the water level of the upper tank by unscrewing the black fitting at the bottom of the overflow.

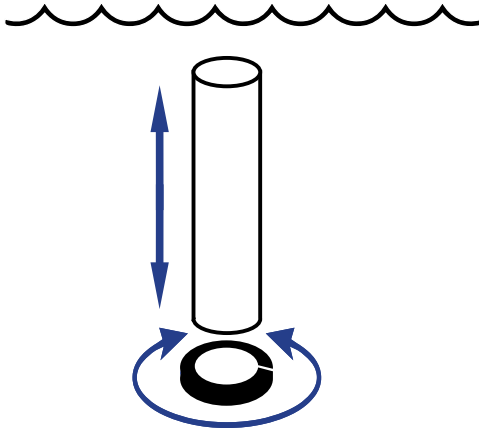

3.5 SALT READING

Perform a salt reading with the hydrometer (Refer to section 5.1)

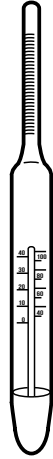

3.6 DISGORGE LOBSTER

Once you have reached the right salination and the water is at the right temperature: Disgorge the lobster before adding them to the tank. (Refer to section 5.3)

3.7 BUILD BACTERIA

To build good bacteria and avoid ammonia reaction, ideally, add the lobster by an increment of 6 weeks:

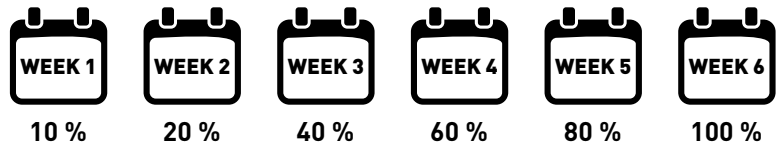

% of the lobster capacity

Note: It will take 10 hours for the coral and charcoal to filter the residues/cloudiness from the water.

**Congratulations,
your installation is complete.**

4. GENERAL MAINTENANCE ROUTINES

4.1 WEEKLY MAINTENANCE



› Wipe daily the water on the metal.

- As a preventative measure, verify the ammonia level for salt and fresh water is equal to or below 0.2 mg per liter. If above 1 mg per liter, execute a water drain (Refer to section 5.5).
- An ammonia reading immediately after adding the lobsters could deliver a false reading.
- Check if the salt level is at 1.024.
- Open the main filter box, discard the dirty top layer filter, and replace it with a new layer by placing it underneath the existing filter layers.

4.2 MONTHLY MAINTENANCE

Verify if the water level is at the right level. (Refer to section 5.4)

- Brush and remove the dust from the cooling fin every month.
- Look inside the electric box where you have the water condensation system to ensure no water or salt accumulation at the bottom.
- Make sure to wipe the salt nearby the compressor as a preventive measure.

4.3 YEARLY INSPECTION AND CLEANING OF THE TANK

Note: Remove the lobsters from the tank to a clean container and store them in a cold room while the technician performs the inspection and deep cleaning of the tank.



- › Never use soap or chemicals to clean the lobster tank since it could contaminate the water.
- › Never use hot water to wash the acrylic basin; therefore, it could cause the plexiglass to crack.

If you do it yourself, here are the instructions:

- Unplug the tank's pump and compressor outlet, making the water recede to the lower tank.
- Add the injector hose to one of the water outlets and connect the garden hose.
- Plugin the electric pump in its respective plug to activate the drainage. Once the lower tank is empty, unplug the pump.
- Remove the filter, coral, and coal of the primary filter (on the side) and secondary filter (in the upper tank). Wipe and clean the residue.
- With the garden hose, rinse the lower tank to wash away the residue on the wall.
- Use a shop vac to vacuum the debris and the water remainder in the lower tank.
- Discard the dirty white filters in each filter box.
- Rinse and drain the coral into a sieve to remove any residue. It can be reused for four years, or replaced if needed.
- Discard the coal and replace with new in the filter boxes, add the coral over, and place four layers of the wool filter on top.
- Refer to Initial Start-up to restart, section 3.

5. TROUBLESHOOTING

5.1 SALT MEASUREMENT WITH HYDROMETER

- Add Aqua's sea salt to the water of the upper tank and stir gently throughout the tank. Wait for the salt to dilute. Test the salinity level to reach 1.024. Write down the recipe on the sticker beside the cooling fin. It will save time when performing a complete drain.

Add the hydrometer to the water in the upper tank.

- If it floats at the green mark level, the salt level is accurate.
- If it floats below the green mark, add more salt.
- If it floats above the green mark, remove saltwater and replace it with fresh water in the upper tank.

The water temperature should be between 44 to 46 Fahrenheit / and 6 to 8 Celsius.



5.2 AMMONIA READING

NOTE: Ammonia reading is required at the initial start-up of the lobster tank for six weeks until the water stabilizes.



- > *Don't perform a test immediately after adding the lobsters to the tank since it could deliver a false reading.*
- > *Do not add more lobsters to the water if the ammonia level is too high.*
- > *If the need for a water drain is caused by ammonia contamination, perform a new test once the tank is cleaned and filled with fresh water. If the ammonia is not in range with the instructions on the box, repeat and perform a second water drain (can be up to 3 times) until the ammonia level is neutral. After that, add the salt, do the salinity test, adjust the water temperature, and add the lobsters.*

5.3 DISGORGE THE LOBSTER

- Lobsters' manure is the number one cause of high ammonia levels. Therefore, we recommend disgorging the lobster upon delivery before adding them to the tank.
- Upon your lobster delivery, we recommend adding only the healthy/fisty lobsters into the tank and discarding or returning the weak ones to your suppliers. The vulnerable lobsters will also contaminate the tank with ammonia, and the one dying.
- Select a clean large plastic container that has never been in contact with any chemicals, soap, detergent, bleach, etc.
- Using a styrofoam box as a second container will also be needed for this operation.
- Prepare the salt recipe with a salinity of 1.024.
- Once you have figured out your salt recipe according to the volume of your container, write down the recipe on the sticker.
- Soak the lobsters in a water bucket at 45 Fahrenheit / 6 Celsius for 15 to 20 minutes. Remove and place them into the Styrofoam box for another 15 to 20 minutes to allow to purge the salted water and expel the manure.
- Transfer the lobsters gently by the tail to the tank one by one.

5.4 WATER LEVEL MONITORING

- Unplug the pump(s) and compressor(s) for the water to recede in the lower tank.
- Check if the water level is at the recommended level indicated MAX in the main filtration box. If not, remove the lobsters into a bucket of water.
- Add the water hose to the overflow tube until it reaches MAX.
- Plugin the appropriate compressor and pump outlet into the right inlet and let the water circulate for 30 min.



> Make sure to plug the proper outlet in the right inlet. Otherwise, it will ruin your pump and compressor!

- Measure the salination, and it should be 1.024 before adding the lobster. (Refer to section 5.1)

5.5 WATER DRAIN

Note: Aqua's filter system allows healthy bacteria to thrive, necessary for the lobster's survival. Emptying the water from your lobster tank should be done within 2 hours, ensuring the survival of the bacteria in the filters.

Note: Remove the lobsters from the tank to a clean container and store them in a cold room.

- Unplug the tank's pump and compressor outlet, making the water recede to the lower tank.
- Add the injector hose to one of the water outlets and connect the garden hose.
- Plugin the electric pump and compressor in their respective plug to activate the drainage. Once the lower tank is empty, unplug both outlets.
- Refer to Initial Start-up p to restart.
- Clean the primary and secondary filter box (Refer to section 4.3.)

5.6 THE WATER HAS A WEAK DEBIT

There's possibly air in the outlet.

- Turn off the pump.
- Put a hose garden in the outlet and turn on the water and the pump. It should remove the air from the outlet.

5.7 ALGAE

The algae growth depends on how much light and Co2 is exposed to and if lobsters are in the tank. Lobsters consume algae, and therefore if you don't have lobsters in the tank, we recommend turning off the tank as it will make the water recede in the bottom tank.



- › *Always keep the UV-protected Lexan cover.*
- › *Do not use any kind of soap or chemicals to clean up the tank. Only use warm water.*
- › *Do not wipe off the algae when there's water in the tank – it will only make things worse.*

Note: Transfer the lobster to a bucket of salted and cold water of 45 Fahrenheit/6 Celsius before any procedures.

- Unplug the tank's pump and compressor outlet, making the water recede to the lower tank.
- Remove the primary and secondary filter box to assess if there is algae or sediment that must be removed and/or cleaned.
- Discard the dirty white filters.
- Remove the algae from the coral by rinsing under water and drain into a sieve. It can be reused for four years, or replaced if needed.
- Discard the coal and replace with new in the filter boxes, add the coral over, and place four layers of the wool filter on top.
- Wipe the interior of the upper tank plexiglass with a soft cloth with warm water.
- Plug the electrical outlet to pump the water to the upper tank.
- Return the lobster gently by the tail into the tank.

5.8 STORING YOUR LOBSTER TANK

- Always drain and clean the tank properly. (Refer to section 5.5)
- Remove the charcoal, coral, and white filters from the primary and secondary filter boxes.
- Discard the white filter and the coal since it is not reusable.
- Rinse and drain the coral into a sieve to remove residue and store it in a bag. It can be reused for four years or replaced if needed.

5.9 MOVING THE LOBSTER TANK

- Always drain the tank properly before moving. (Refer to section 5.5)
- Unlock the wheels before moving the tank.
- Always move the tank by the rigid lower part.
- Never push or pull the tank by the plexiglass upper part.

FAQ

WHAT TO DO THE LOBSTERS ARE DYING?

- Make sure that soap, hand sanitizer, or other types of chemicals are not in contact with the tank and its water which will cause the shellfish to die.
- Always disgorge the lobsters before adding them to the tank. (Refer to section 5.3)
- Discard the weak and dying lobsters from the tank.
- Verify if the salinity of the water is at 1.024 refer and that the water temperature is between 45 to 46 Fahrenheit / 6 to 8 Celsius. (Refer to section 5.1)
- Verify the ammonia level, refer to the instructions on the ammonia box.
- If the tests are abnormal, perform a complete drain (Refer to section 5.5) discard the filter components, and replace them with new ones.
- Fill up the tank (Refer to section 3)

WHAT IS THE IDEAL WATER TEMPERATURE FOR LOBSTERS?

- The water temperature should be between 46 and 48 Fahrenheit / 6 and 8 Celsius. It is regulated by a thermostat and pre-set by the manufacturer. If you suspect not working accordingly, please get in touch with us.

DO LOBSTERS NEED TO BE FED?

- There's no need to feed due to the cold-water temperature making the lobster hibernate.

HOW LONG WILL THE LOBSTERS LIVE IN THE TANK?

- Under perfect conditions, they can live up to 2 months.

HOW TO VERIFY MY SALT LEVEL?

- Refer to the troubleshooting/salt measurement with a hydrometer.

HOW TO VERIFY MY AMMONIA LEVEL?

- Refer to the troubleshooting/ammonia reading.

WHY IS THE WATER CLOUDY?

- The lobster's fecal may cloud up the water. Therefore it is essential to disgorge the lobsters before adding them to the tank. (Refer to section 5.3)
- The ammonia level may be too high. Conduct a test and follow the instructions on the ammonia box (Refer to section 5.2)

WHY IS THE WATER TEMPERATURE WARM INSTEAD OF COLD?

- Verify if the thermostat light is on. If yes, contact us.

WHY IS THE WATER TEMPERATURE BELOW 39 Fahrenheit / 4 C?

- Verify if the pump outlet is plugged into the respective pump inlet. If correct, unplug the tank. Contact us.

WHY ARE BUBBLES COMING OUT OF THE WATER OUTLET?

- It might be the pump pulling in air. It could be life-threatening for the lobsters and might damage the pump.
- Quickly correct the water level (Refer to section 5.4)
- Verify if the pump outlet is connected to its respective inlet.

WHY IS THE WATER LEVEL LOW?

- Natural evaporation and absorption by lobsters cause the water level to decrease. We recommend verifying the water level every three months. (Refer to section 5.4)

WHY IS THE WATER DEBIT WEAK?

- Refer to Trouble Shooting Air

HOW OFTEN DO I NEED TO EMPTY MY TANK?

- It depends on the lobster inventory you handle throughout the year. The key is to disgorge the lobsters upon the delivery, keep the white filter clean and perform regular maintenance as per our suggestion to preserve the water clean.

HOW CAN I FILL UP THE TANK?

- Refer to Initial Start up on p.

HOW LONG DOES CORAL LAST?

- You can rinse it as many times as needed and reuse up to 4 years.

HOW LONG DOES CHARCOAL LAST?

- It can last up to 1 year. It can not be rinsed and reused.

HOW TO STORE MY TANK?

- Refer to section 5.8

HOW TO MOVE MY TANK?

- Refer to section 5.9

